

# **DriMaster III HiFlo Stainless Steel Upholstery Tool Owner's Manual**

**Models 000-163-221 and 000-163-223**

---

**HydraMaster  
11015 47<sup>th</sup> Avenue West  
Mukilteo, Washington 98275**

MAN-45987 Rev. 0 February 28, 2014  
(000-182-405)

No part of this manual may be reproduced or used in any form or by any means (i.e. graphic, electronic, photocopying or electronic retrieval systems) without the express written permission of HydraMaster. Specifications and information in this document are subject to change without prior notice. All rights reserved. © 2014 HydraMaster

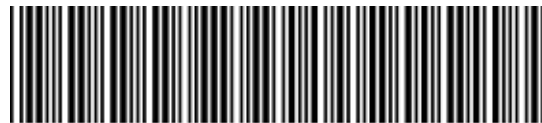

\*000-182-405\*

This page intentionally left blank.



# Table of Contents

<b>GENERAL INFORMATION.....</b>	<b>SECTION 1</b>
Contact Information.....	1-2
Warnings, Cautions and Notices.....	1-3
<b>OPERATING INSTRUCTIONS.....</b>	<b>SECTION 2</b>
Optional Accessory Handle Assembly (P/N 000-061-144).....	2-2
Begin Cleaning.....	2-3
<b>TOOL MAINTENANCE.....</b>	<b>SECTION 3</b>
Cleaning Bar Jet Assembly.....	3-1
Cleaning the Filter Cartridge and Orifice Plate.....	3-2
<b>ASSEMBLIES AND PARTS LISTS.....</b>	<b>SECTION 4</b>
HiFlo Handpiece with Hose Assembly Parts List.....	4-4
HiFlo Handpiece without Hose Assembly Parts List.....	4-6
Knob Assembly Parts List.....	4-7
Hide-a-Hose Assembly Parts List.....	4-9
Bar Jet Assembly Parts List.....	4-10
Handle Accessory Assembly Parts List.....	4-11
<b>HOW TO ORDER PARTS.....</b>	<b>SECTION 5</b>
Warranty Parts Orders.....	5-1
Parts Orders.....	5-1
Emergencies.....	5-1
<b>WARRANTY INFORMATION.....</b>	<b>SECTION 6</b>



# List of Figures

Figure 1-1. DM III Shown with Hide-A-Hose Attached.....	1-1
Figure 1-2. DM III Shown with Optional Accessory Handle .....	1-1
Figure 2-1. Attach Optional Accessory Handle to the DM III .....	2-2
Figure 2-2. Attach Solution Hose and Adjust Solution Control Knob.....	2-3
Figure 2-3. Turning Knob to “HiFlo” Position Forms Sheet of Solution Across Bar Jet.....	2-4
Figure 3-1. Clean Bar Jet Assembly with Feeler Gauge.....	3-1
Figure 3-3. Remove Filter Cartridge and Orifice Plate .....	3-2
Figure 3-2. Disassemble Quick Connect.....	3-2
Figure 3-4. Remove Four 4-40 Screws from Nose of Tool .....	3-4
Figure 3-5. Re-install Nose.....	3-4
Figure 4-1. Adhesive/Sealant Material Reference .....	4-2
Figure 4-2. HiFlo Handpiece with Hose Assembly .....	4-3
Figure 4-3. HiFlo Handpiece without Hose Assembly .....	4-5
Figure 4-4. Knob Assembly .....	4-7
Figure 4-5. Hide-a-Hose Assembly.....	4-8
Figure 4-6. Bar Jet Assembly .....	4-10
Figure 4-7. Handle Accessory Assembly .....	4-11

# 1 - General Information

Congratulations on purchasing the very latest in upholstery cleaning technology.

The patented DriMaster III HiFlo Stainless Steel Upholstery Tool, shown in Figure 1-1, is perfect for cleaning upholstery, fabric and stairs. It has no trigger valve and never needs a separate dry pass.\*



**Figure 1-1. DM III Shown with Hide-A-Hose Attached**

The tool's new design incorporates light weight, extremely durable materials, giving the tool increased levels of strength and comfort.

The DriMaster III HiFlo Stainless Steel Upholstery Tool accommodates high volume jobs where production rate is important.

It is capable of solution flow rates for jobs that require a flushing action which makes the tool particularly efficient for stair cleaning.

An optional accessory handle, shown attached to the tool in Figure 1-2, is available to increase comfort on long cleaning jobs.

We trust that you will enjoy many years of reliable upholstery cleaning with the DriMaster III HiFlo Stainless Steel Upholstery Tool.



**Figure 1-2. DM III Shown with Optional Accessory Handle**

## NOTICE

The DriMaster III HiFlo Stainless Steel Upholstery Tool can be used with a variety of HydraMaster cleaning systems.

\* U.S. Patent No. RE41,367; 7,070,662; RE39,623; D590,111



## CONTACT INFORMATION

If you have any questions regarding the operation, maintenance or repair of this tool, please contact your local distributor.

To find a local distributor, please visit our website at <http://hydramaster.com/HowToBuy/DealerLocator.aspx>.

If your question cannot be resolved by your distributor or by the information within this manual, you may contact HydraMaster direct using the following phone numbers.

HOURS	TELEPHONE NUMBERS	E-MAIL ADDRESSES
Monday-Friday 7:00 a.m. to 5:00 p.m. Pacific Time	<b>Technical Support</b> (425) 775-7275 FAX : (800) 426-4225	<b>Technical Support</b> techsupport@hydramaster.com
	<b>Customer Service/Parts</b> (425) 775-7276 FAX: (425) 771-7156	<b>Customer Service/Parts</b> parts@hydramaster.com

When calling your distributor, be sure to reference the date of purchase.

### FOR YOUR REFERENCE:

**Date of Purchase:** \_\_\_\_\_

**Purchased From (Distributor):** \_\_\_\_\_

## WARNINGS, CAUTIONS AND NOTICES

### **⚠ WARNING**

HydraMaster uses this WARNING symbol throughout the manual to warn of possible injury or death.

### **CAUTION**

This CAUTION symbol is used to warn of possible equipment damage.

### **NOTICE**

This NOTICE symbol indicates that federal or state regulatory laws may apply, and also emphasizes supplemental information.



This page intentionally left blank.



## 2 - Operating Instructions

Your DriMaster III HiFlo Stainless Steel Upholstery Cleaning Tool has been engineered using the latest and most sophisticated technology available to produce the finest upholstery cleaning results possible. Despite this, it remains only a tool of the upholstery cleaning trade and can produce only as good a job as the person operating it.



**HydraMaster strongly recommends attending an Institute of Inspection, Cleaning and Restoration Certification (IICRC) approved Upholstery Cleaning course as soon as possible and to always follow the IICRC guidelines when cleaning.**



### OPTIONAL ACCESSORY HANDLE ASSEMBLY (P/N 000-061-144)

The DriMaster III HiFlo Stainless Steel tool can be equipped with an optional accessory handle (purchased separately) to increase comfort and control during difficult or extended repetitive use of the upholstery tool.

1. Attach the left and right handles (items 3 and 4 - see Figure 2-1) to the DM III.
2. The shorter screws, nuts, and washers (items 2, 5 and 6) are used on the upper handle.
3. The longer screws, nuts and washers (items 1, 5 and 6) are used to connect the assembled handle to the tool body.

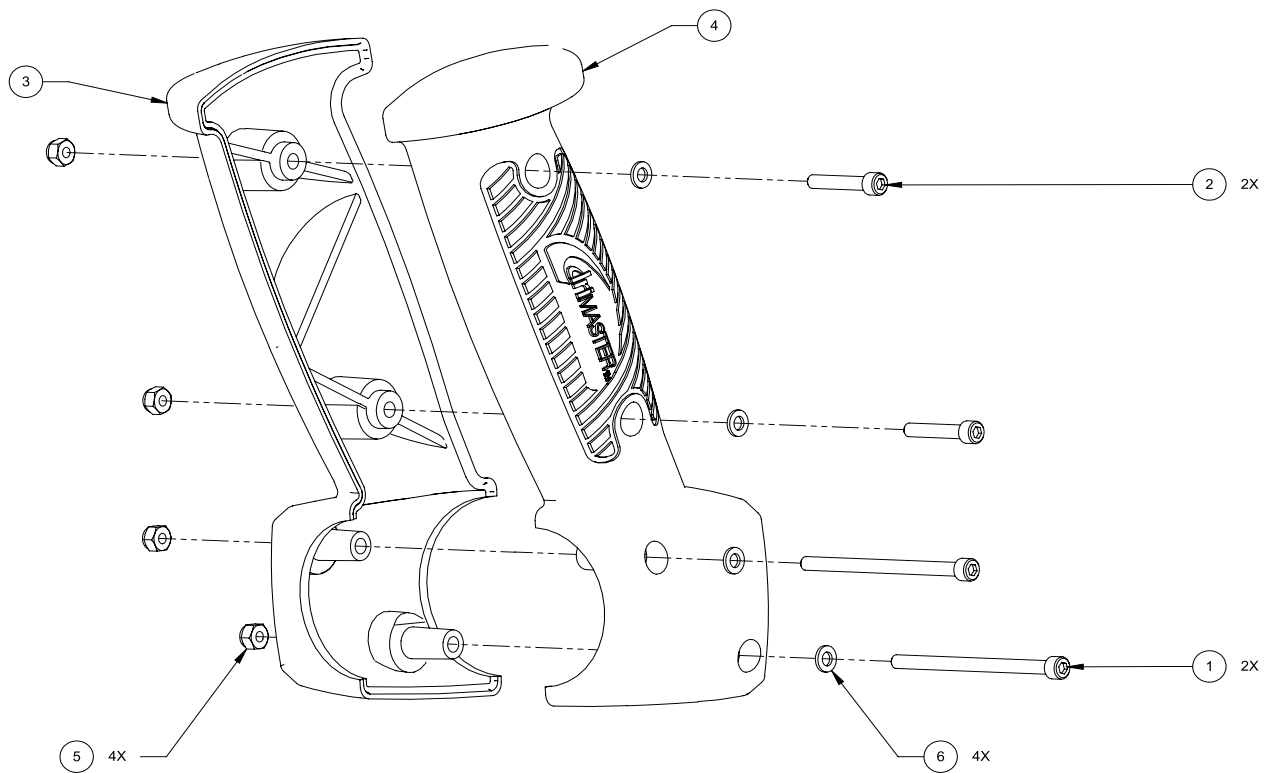

**Figure 2-1. Attach Optional Accessory Handle to the DM III**

## BEGIN CLEANING

### **⚠ WARNING**

Do not use the DriMaster III on a machine exceeding 14" Hg vacuum and 500 psi solution pressure. Personal injury could result.

1. Attach the solution hose to the solution quick connect. A 1 ½" - 2" vacuum hose can be attached to the vacuum hose manifold (see Figure 2-2).

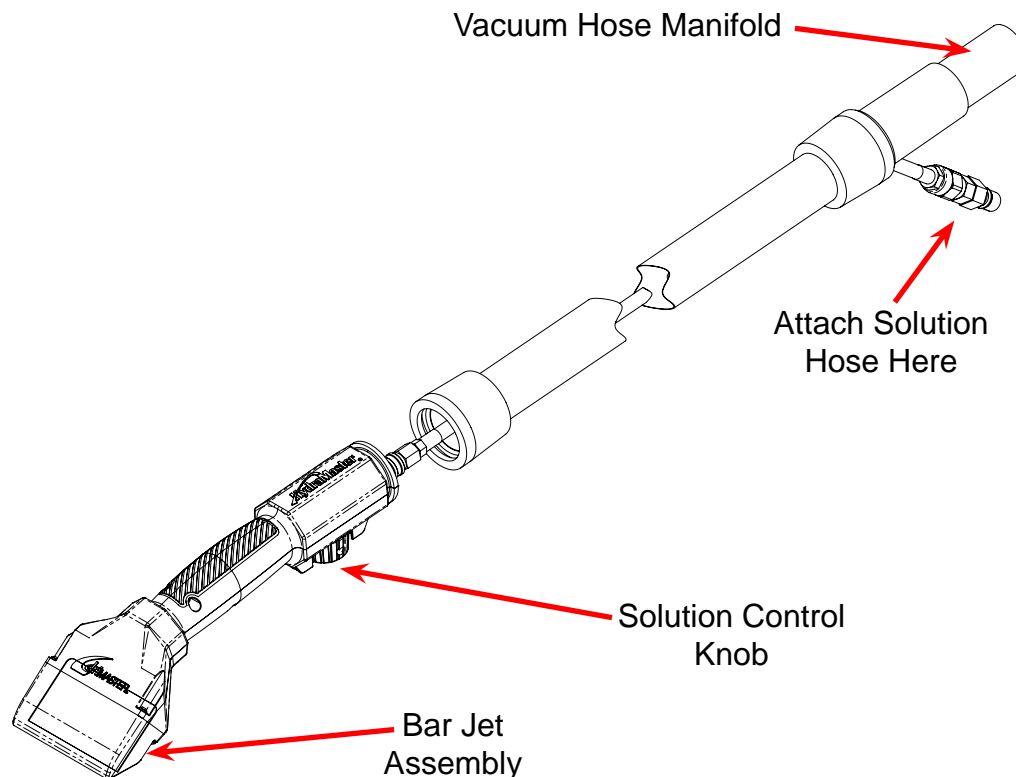
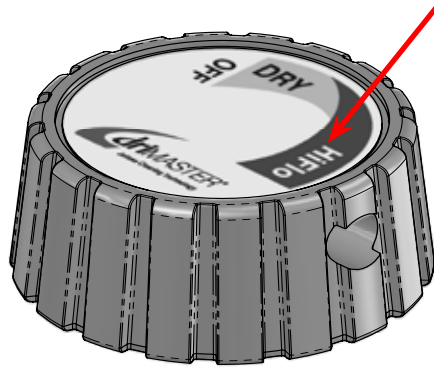

**Figure 2-2. Attach Solution Hose and Adjust Solution Control Knob**

2. Adjust the solution volume by turning the solution control knob. Turning the knob counterclockwise increases the solution volume; turning the knob clockwise decreases the solution volume. The amount of solution volume you need will vary with the type of machine you are cleaning with and the type of material you are cleaning.
3. To begin adjustment, make sure the cleaning machine is running and both vacuum and solution hoses are connected.
4. Slowly open the solution control knob until solution is flowing across the entire bar jet (without overspray).



When the solution knob is turned toward the “HiFlo” position, the solution will form a liquid “sheet” across the bar jet (see Figure 2-3)



**Figure 2-3. Turning Knob to “HiFlo” Position  
Forms Sheet of Solution Across Bar Jet**

### **NOTICE**

The amount of vacuum and pressure produced by your machine will determine the overspray on the bar jet assembly.

### **⚠ WARNING**

Do not touch the bar jet assembly during operation or immediately afterward; doing so may cause severe burns.

### **CAUTION**

When cleaning stairs, do not allow the tool to come into contact with the tack strip along the edges of the stairs. The tool’s cleaning surface may be damaged by the tack strip. Equipment damage such as this is not covered by warranty.

# 3 - Tool Maintenance

## CLEANING BAR JET ASSEMBLY

The bar jet assembly needs to be cleaned with a 0.015" feeler gauge.

1. Slide the feeler gauge into the small slot (see Figure 3-1).
2. Gently slide the gauge back and forth to clear any debris from the opening

### CAUTION

Use only a feeler gauge to clean the slot in the bar jet. Use of any other implement (paper clip, knife blade) may damage the opening and seriously reduce the cleaning effectiveness of the upholstery tool.



**Figure 3-1. Clean Bar Jet Assembly with Feeler Gauge**

### NOTICE

HydraMaster recommends you clean the filter cartridge and orifice plate on a periodic basis to eliminate hard water deposit buildup. Both components are conveniently located in the Hide-a-Hose solution quick connect (see Figure 3-2).

See page 3-4 for additional cleaning information.

### **CLEANING THE FILTER CARTRIDGE AND ORIFICE PLATE**

1. Disassemble the Hide-a-Hose quick connect to gain access to the filter cartridge and orifice plate (see Figure 3-2 and Figure 3-3).
2. Remove the filter cartridge and orifice plate, place them in a cup full of white vinegar and soak for 30 minutes.

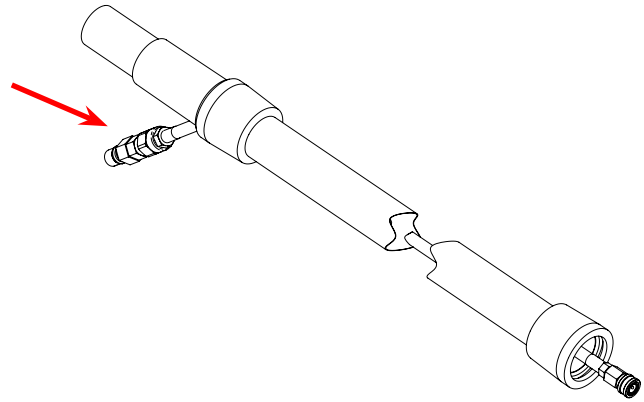

**Figure 3-2. Disassemble Quick Connect**

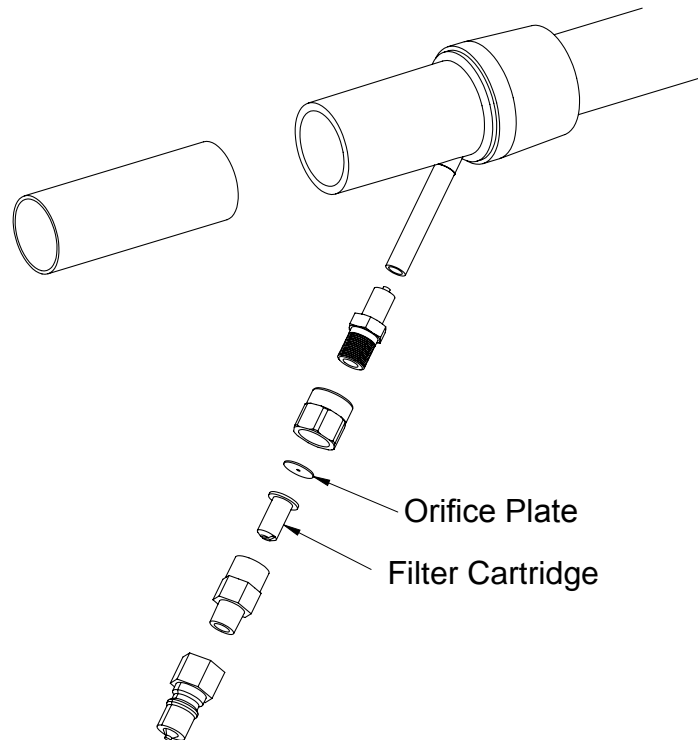

**Figure 3-3. Remove Filter Cartridge and Orifice Plate**

3. Clean the orifice plate's opening with a wooden skewer or a similar tool such as a plastic pick.

### **CAUTION**

Do not use a metal object to clean the opening of the orifice plate; doing so can damage the plate.

4. Remove both parts from the vinegar and thoroughly rinse them with clean water.
5. Re-assemble the solution quick connect, re-installing the filter cartridge and orifice plate in the proper order (see Figure 3-3).

### **CAUTION**

Do not operate the DriMaster III without the orifice plate installed. If you do not properly re-install the orifice plate in the solution quick connect as indicated in Figure 3-3, equipment damage could result. Such equipment damage is not covered by warranty.

## NOTICE

It may be necessary to periodically clean the inside of the tool, hose and manifold. Debris can build up over time, restricting the air flow.

Follow this procedure to disassemble the tool and clean the interior:

1. Remove the nose of the tool by first removing the four 4-40 screws using an Allen head wrench (see circled screws in Figure 3-4).

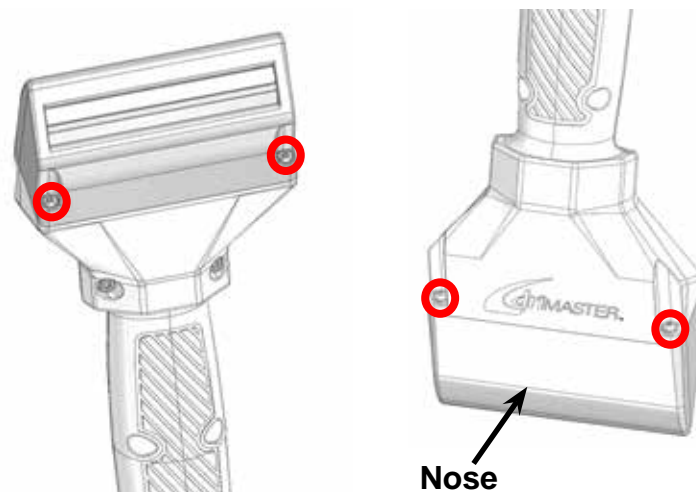

**Figure 3-4. Remove Four 4-40 Screws (Circled) from Nose of Tool**

2. Clear any debris build up from the interior of the tool.
3. Re-install the nose, carefully ensuring that the bar jet assembly enters the space between each mounting groove inside the end of the nose (see Figure 3-5).

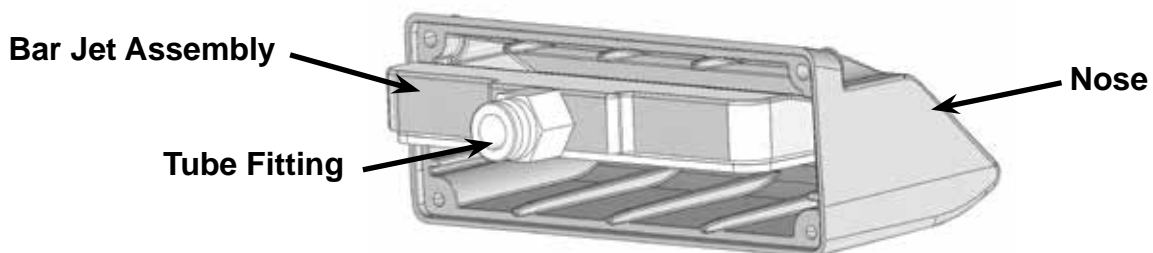

**Figure 3-5. Re-install Nose**



4. Carefully fit the nose to the end of the tool body while aligning the mounting flange over the top and bottom halves of the tool.
5. After the nose is seated, install the four 4-40 mounting screws using the thread locker indicated in Figure 4-2.

## NOTICE

The material of the nose can slowly wear down over time, due to regular use; this is typical and is not considered a warranty issue.

HydraMaster recommends that the operator/distributor stock replacement parts in the service vehicles.



This page intentionally left blank.

# 4 - Assemblies and Parts Lists

This section of the manual shows the DM III assembly illustrations.

Some of the illustrations in this section reference sealants, thread lockers, adhesive, primer, anti-seize and lubricant specifications that are used in the construction of HydraMaster equipment.

Refer to Figure 4-1 to identify those substances such as A1, A2 and so forth. Equivalent products are acceptable if they meet or exceed current specifications and are approved by HydraMaster.

Adhesive Material Production Line Reference Card from ENG-45975 Rev. 0

<p><b>A1</b> Silicone RTV</p> 	<p><b>A2</b> Loctite 567</p> 	<p><b>A3</b> Loctite 545</p> 	<p><b>A4</b> Teflon Tape</p> 	<p><b>E1</b> Loctite 51252 Grease</p> 	
<p><b>B1</b> Loctite 242</p> 	<p><b>B2</b> Loctite 262</p> 	<p><b>B3</b> Loctite 266</p> 	<p><b>C1</b> Gapper</p> 	<p><b>D1</b> Loctite 7649</p> 	<p><b>E2</b> Molykote Anti-Seize</p> 
<p><b>B4</b> Loctite 222MS</p> 	<p><b>B5</b> Loctite 425</p> 	<p><b>E4</b> Super Lube</p> 	<p><b>E5</b> SFK Anti-Fret</p> 		

Figure 4-1. Adhesive/Sealant Material Reference

**Figure 4-2. HiFlo Handpiece with Hose Assembly**  
000-163-221 Rev. E

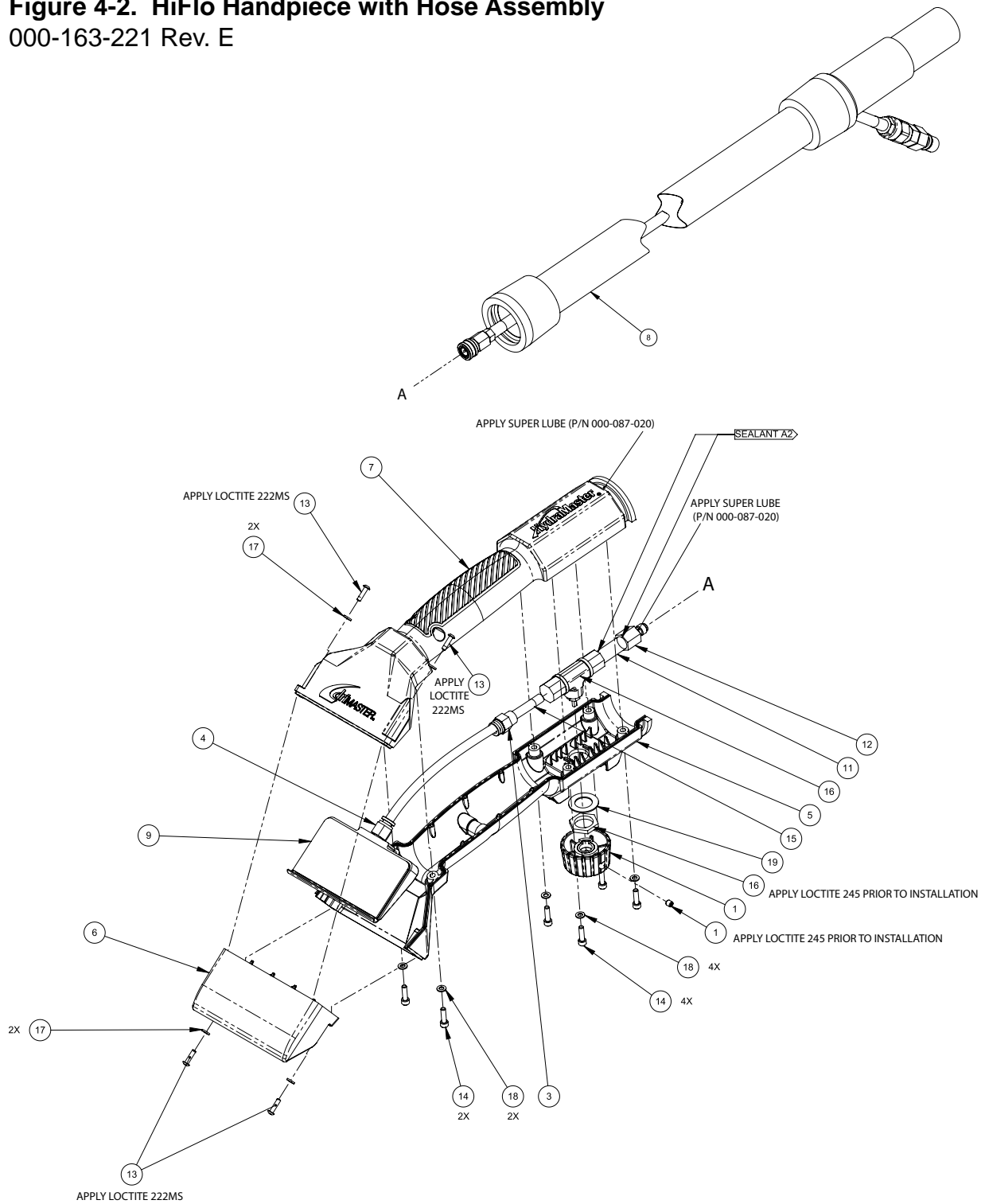

**NOTICE**

See Figure 4-1 for adhesive/sealant material Information.



## HiFlo Handpiece with Hose Assembly Parts List

Item	Part Number	Description	Qty
1	000-061-146	Assembly, Knob Custom Insert with Label	1
2	000-014-006	Box, 15 X 15 X 10 (not shown on drawing)	1
3	000-052-562	Fitting, 1/8" NPT X 1/4" One Touch	1
4	000-052-563	Fitting, 10-32" NPS X 1/4" One Touch	1
5	000-061-186	Handle, Body - Bottom	1
6	000-061-187	Handle, Body - Nose	1
7	000-061-185	Handle, Body - Top	1
8	000-068-810	Hose, Hide-A-Hose S/S Assembly	1
9	000-076-071	Jet Assembly Weldment	1
10	000-182-405	Manual, DM III S/S Tool (not shown on drawing)	1
11	000-052-782	Nipple, 1/8" NPT X 1.5" Lg.	1
12	000-052-783	Quick Disconnect, Male 1/8" NPT	1
13	000-143-351	Screw, 4-40" X 7/16" Lg. S/S Button Head	4
14	000-143-350	Screw, 6/32" X 1/2" Lg. S/S Allen Head - Self Locking	6
15	000-125-350	Tube, 1/4" O.D. X 7.25" Lg.	1
16	000-169-222	Valve, Ball	1
17	000-174-182	Washer, #4 Flat	4
18	000-174-167	Washer, Flat 0.143" I.D. X 0.267" X O.D.0.032"	6
19	000-174-168	Washer, Flat, .875 O.D. X .515 I.D. X .035 Thk	1

**Figure 4-3. HiFlo Handpiece without Hose Assembly**  
000-163-223 Rev. A

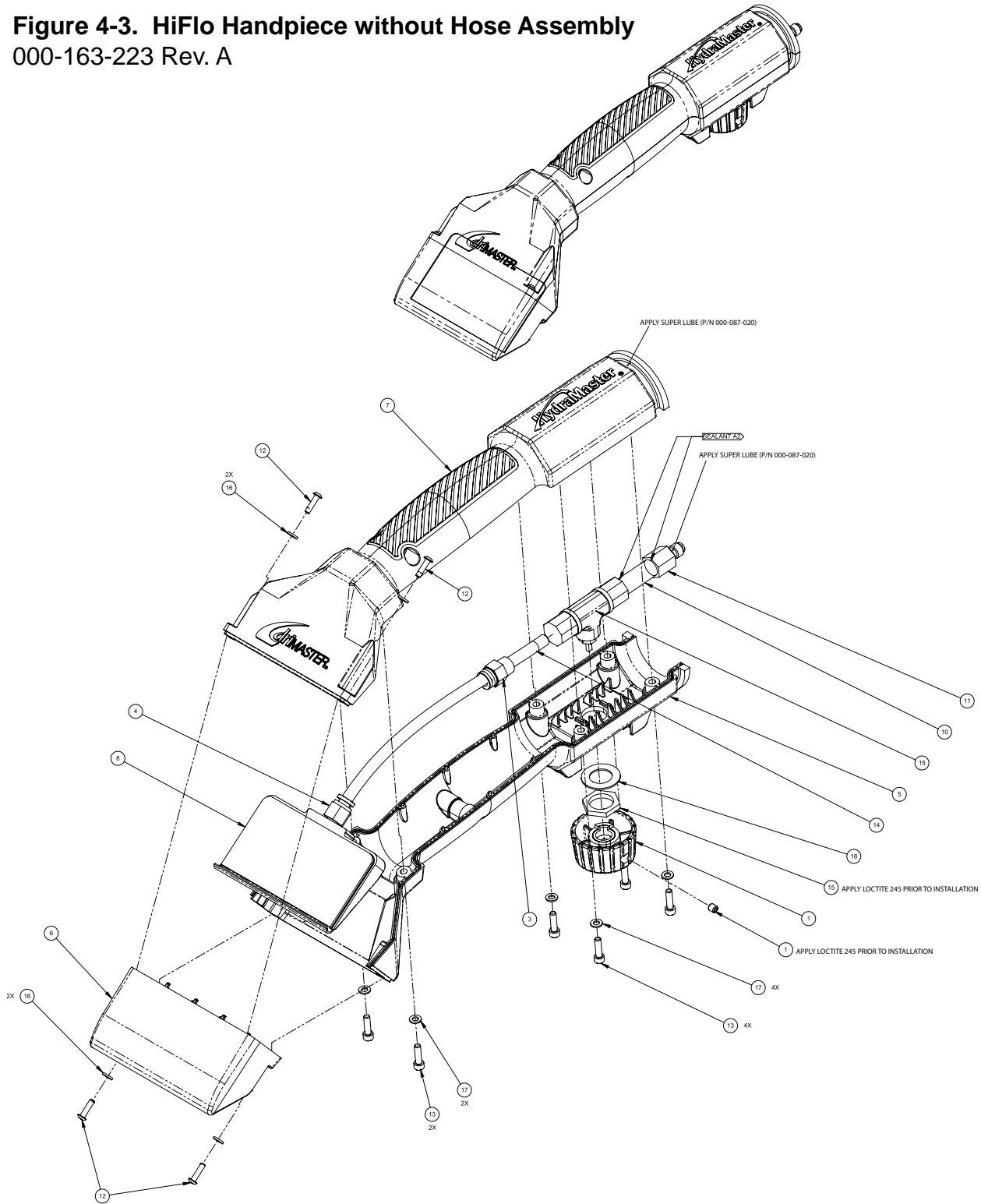

**NOTICE**

See Figure 4-1 for adhesive/sealant material Information.



## HiFlo Handpiece without Hose Assembly Parts List

Item	Part Number	Description	Qty
1	000-061-146	Assembly, Knob Custom Insert with Label	1
2	000-014-006	Box, 15 X 15 X 10 (not shown on drawing)	1
3	000-052-562	Fitting, 1/8" NPT X 1/4" One Touch	1
4	000-052-563	Fitting, 10-32" Nps X 1/4" One Touch	1
5	000-061-186	Handle, Body - Bottom	1
6	000-061-187	Handle, Body - Nose	1
7	000-061-185	Handle, Body - Top	1
8	000-076-071	Jet Assembly Weldment	1
9	000-182-405	Manual, DM III S/S Tool (not shown on drawing)	1
10	000-052-782	Nipple, 1/8" NPT X 1.5" Lg.	1
11	000-052-783	Quick Disconnect, Male 1/8" NPT	1
12	000-143-351	Screw, 4-40" X 7/16" Lg. S/S Button Head	4
13	000-143-350	Screw, 6/32" X 1/2" Lg. S/S Allen Head - Self Locking	6
14	000-125-350	Tube, 1/4" O.D. X 7.25" Lg.	1
15	000-169-222	Valve, Ball	1
16	000-174-182	Washer, #4 Flat	4
17	000-174-167	Washer, Flat 0.143" I.D. X 0.267" X O.D.0.032"	6
18	000-174-168	Washer, Flat, .875 O.D. X .515 I.D. X .035 Thk	1



**Figure 4-4. Knob Assembly**  
000-061-146 Rev. B

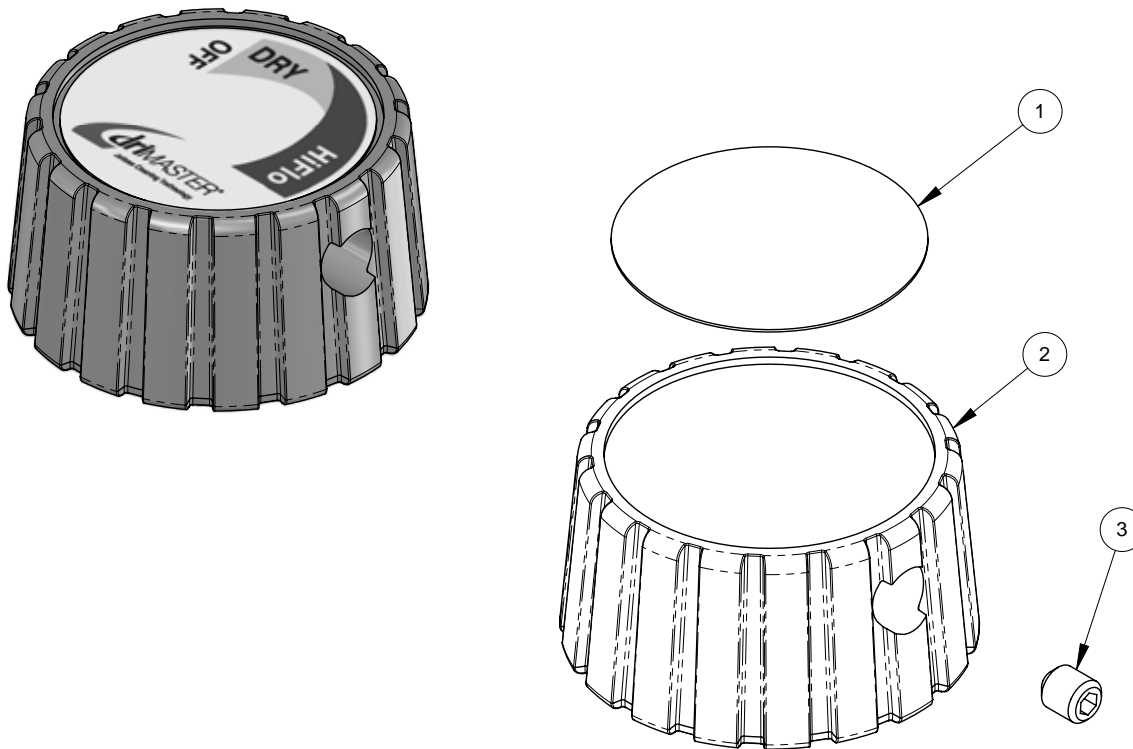

### Knob Assembly Parts List

Item	Part Number	Description	Qty
1	000-081-251	Label, Knob - Flow Control	1
2	000-061-145	Knob Assembly, Flow Control Valve	1
3	000-143-374	Screw, #8/32UNC X 0.188 " Lg. Set	1

**Figure 4-5. Hide-a-Hose Assembly**  
000-068-810 Rev. E

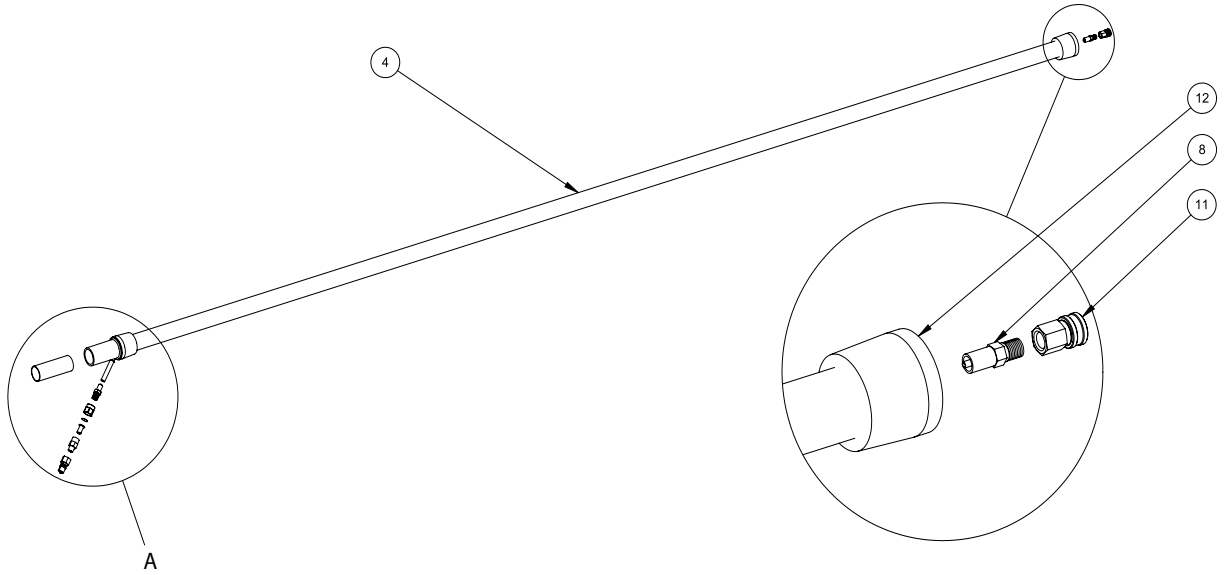

**VIEW A**

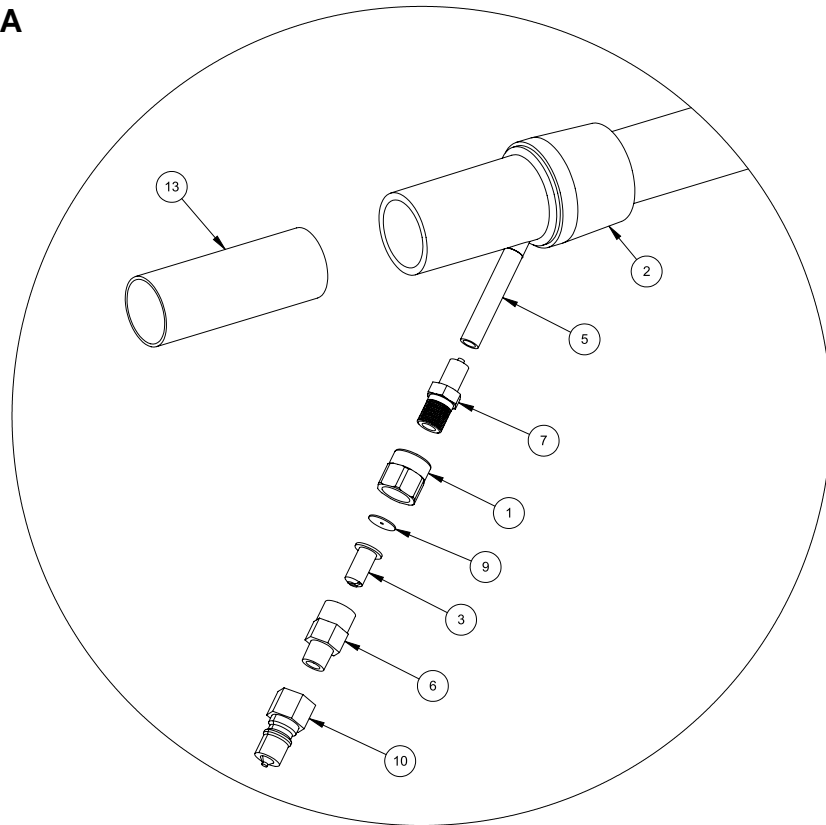

## Hide-a-Hose Assembly Parts List

Item	Part Number	Description	Qty
1	000-052-804	Adapter, S/S. Jet X 1/4" FNPT	1
2	000-052-807	Cuff - Solution Hose 1/4" *	1
3	000-049-253	Filter Cartridge, 1/4" S/S	1
4	000-068-036	Hose, 1.5" Vacuum - Gray X 1 ft Lg. *	1
5	000-068-811	Hose, 1/8" X 120" Lg. *	1
6	000-052-803	Housing, 1/4" S/S Filter	1
7	000-052-811	Insert, 1/8" Hose X 1/4" MNPT S/S *	1
8	000-052-810	Insert, 1/8" Hose X 1/8" MNPT S/S *	1
9	000-180-024	Orifice, Plate 0.067"	1
10	000-052-516	Quick Connect, 440 Male w/ Viton Std	1
11	000-052-805	Quick Connect, Female, 1/8" - Open	1
12	000-052-806	Swivel Cuff - Half *	1
13	000-125-248	Tube, 1.5" S/S *	1

### NOTICE

\* The parts marked with an asterisk are not for sale, individually. To order any of these parts, please order P/N 000-068-810.



**Figure 4-6. Bar Jet Assembly**  
000-076-071 Rev. A

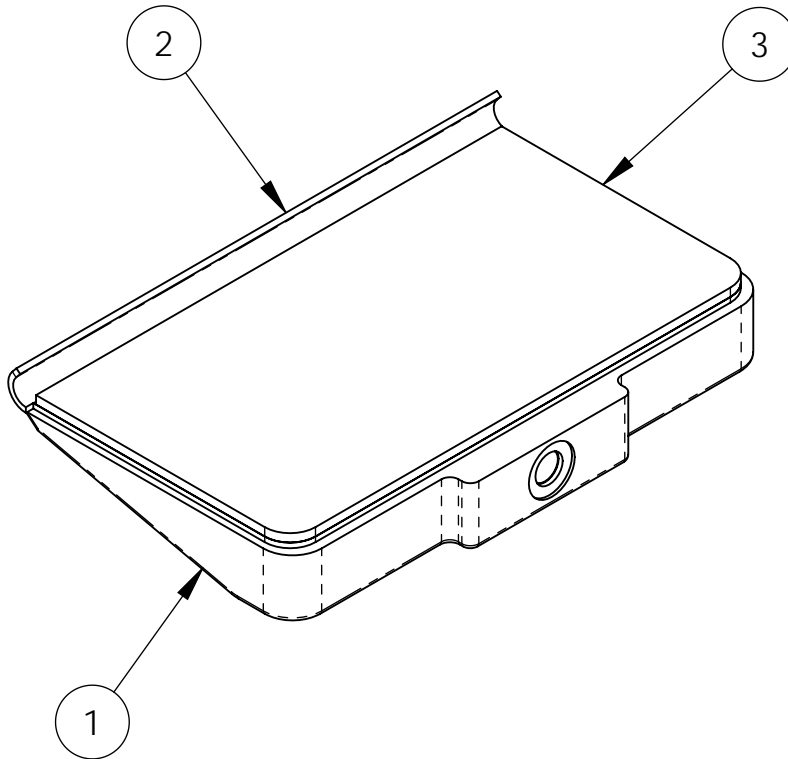

### Bar Jet Assembly Parts List

Item	Part Number	Description	Qty
1	000-076-096	Jet, Bar, Cast - w/ 10-32UNF	1
2	000-105-558	Plate, Top Jet - Continuous Radius	1
3	000-105-529	Plate, Top Jet - Spacer	1

**Figure 4-7. Handle Accessory Assembly**  
000-061-144 Rev. D

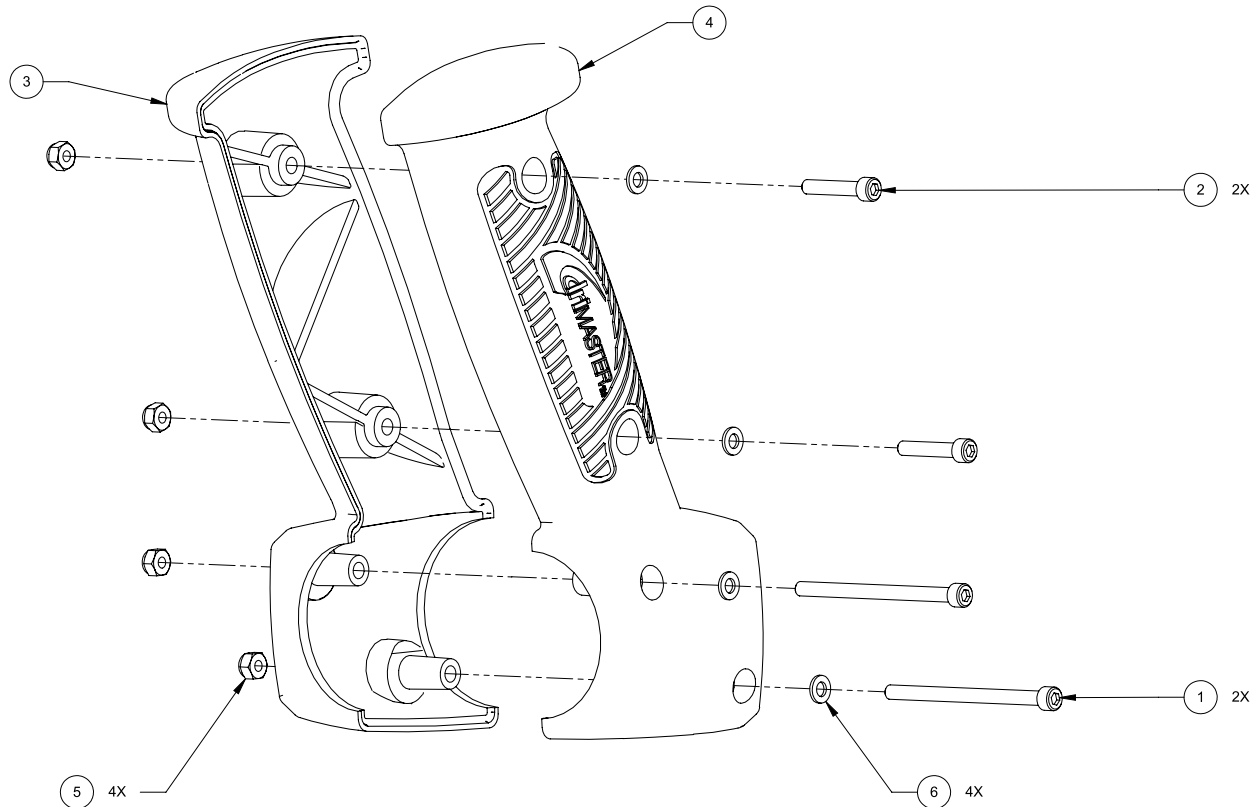

### Handle Accessory Assembly Parts List

Item	Part Number	Description	Qty
1	000-143-579	Cap Screw, Socket Head, #6-32 X 2	2
2	000-143-577	Capscrew, Socket Head, 6-32 X 3/4	2
3	000-061-141	Handle, Accessory, Left	1
4	000-061-142	Handle, Accessory, Right	1
5	000-094-063	Nut, #6-32UNC Nylock	4
6	000-174-167	Washer, Flat 0.143" I.D. X 0.267" X O.D. 0.032"	4



This page intentionally left blank.

# 5 - How to Order Parts

From time to time, cleaning equipment may wear out or malfunction. To obtain a proper diagnosis of your malfunction, and to order warranty replacement parts or arrange for repairs, it is important that you proceed in the following manner:

## **WARRANTY PARTS ORDERS**

1. Call the local distributor where you purchased your equipment and ask for the Service Department.
2. Have the following information ready:
  - a. Equipment Model
  - b. Date of Purchase
  - c. Description of Malfunction
3. Once it has been determined which parts are needed to correct the problem with your tool, make arrangements with your distributor to either perform the repairs or ship the parts to you.

## **PARTS ORDERS**

Call your local distributor. In most instances, they either stock or have access to parts through a regional service center.

## **EMERGENCIES**

If, for any reason, your distributor is unable to supply you with the necessary parts, they may call us and arrange for expedited shipping.

HydraMaster sells parts only through authorized distributors and service centers.

We shall always endeavor to be fair in our evaluation of your warranty claim, and shall provide you with a complete analysis of our findings.



This page intentionally left blank.





## 6 - Warranty Information

All parts of the Upholstery Tool are warranted against defects as stated in the Golden Guarantee© Limited Warranty document which is shipped to you with this Owner's Manual. Refer to HydraMaster's website at:

<http://hydramaster.com/KnowledgeCenter/Warranty.aspx>

Warranty coverage is available to you through your local distributor.

HydraMaster warranty covers only defective materials and/or workmanship for the period listed. Labor and/or diagnostic reimbursement is specifically excluded.

If you have moved to a new area or have purchased a used machine and need information regarding your local distributor, call HydraMaster at (425) 775-7272 or email us at: [custsvc@hydramaster.com](mailto:custsvc@hydramaster.com).



This page intentionally left blank.



## GOLDEN GUARANTEE® LIMITED WARRANTY PLAN

HydraMaster machine owners enjoy the most comprehensive warranty protection available in the truckmount industry. All components, large or small are included in the Warranty Plan, providing the owner with real warranty coverage against any part failure, large or small. Our machines are designed with a richness of detail and with many labor-saving features. The elegant simplicity of our design will always outperform more complicated equipment in the long haul. While HydraMaster equipment is extremely reliable and we endeavor to use only top quality components, if a malfunction should occur you'll see why they call HydraMaster "Customer Friendly". We look forward to having you as a member of HydraMaster's family of satisfied machine owners.

HydraMaster warrants truckmount machines of its manufacture to be free from defects in material and workmanship if properly installed, maintained, and operated under normal conditions with competent supervision. No person, agent, representative or dealer is authorized to give any warranties on behalf of HydraMaster nor to assume for HydraMaster any other liability in connection with any HydraMaster products. This warranty shall extend to the original purchaser of said equipment for the periods listed below from date of installation. This warranty is non-transferrable. To ensure the functionality and safety of this equipment, if repairs, replacements or modifications are made by the Purchaser without HydraMaster's consent, HydraMaster's warranty shall cease to be in effect.

Machinery, equipment and accessories furnished by HydraMaster, but manufactured by others, are warranted only to the extent of the original manufacturer's warranty to HydraMaster unless otherwise specified in the listing below.

HydraMaster agrees, at its option, to repair at the point of shipment, or to replace without charge any parts or parts of products of HydraMaster's manufacture, which within the specified warranty period shall be proved to HydraMaster's satisfaction to have been defective when shipped, provided the purchaser promptly notifies HydraMaster, in writing, of such alleged defect. HydraMaster will pay all freight and transportation charges within the United States, via normal ground shipping means, for replacement of parts covered under this warranty.

This warranty covers parts, as specified, and labor which may be necessary in completing repairs. HydraMaster's liability to Purchaser, whether in contract or in tort arising out of warranties, representation, instructions, or defects from any cause shall be limited to repairing or replacing the defective part or parts using new or remanufactured parts. To qualify for warranty coverage, defective parts must be returned to HydraMaster within 60 days under an assigned RMA. No liability whatsoever shall attach to HydraMaster until said products have been paid for.

Except as stated in this section and in the proceeding section and except as to title, there are no guarantees or warranties of merchantability, fitness, performance or otherwise, express, implied or statutory, and HydraMaster shall have no liability for consequential, incidental, or other damages, howsoever caused, including but not limited to lost business, downtime, lodging. Parts supplied under this warranty will themselves be warranted only for the remaining time left in the original warranty period.

All components not specifically referenced in the schedule below are covered under this warranty for a period of two (2) years, excepting those parts which are considered, by HydraMaster, to be expendable in normal use, including but not limited to paint, labels and other cosmetic parts or features.

Freezing of any water or chemical related component will VOID all warranties on water or chemical related components, internal or external, of this equipment.

Corrosion, deposits and/or build-up in the water, chemical, recovery or heating systems due to hardness in the water used or chemicals which results in deposits, will VOID all warranties on affected components.

The use or application of any chemical, including but not limited to acids or solvents, which results in damage to metal, rubber, plastic, or painted parts will VOID all warranties on those parts.

- FRAME, COVER ASSEMBLIES:** 3 years
- VACUUM RECOVERY TANK (Structural):** 3 years
- ENGINE:** As provided by original Manufacturer's Warranty
- VACUUM BLOWER: (Uncontested Through Tuthill)** 2 years
- CHEMICAL SYSTEMS:** 2 years
- INTERNAL MACHINE HOSES:** 2 years
- HIGH PRESSURE BY-PASS VALVE:** 2 years
- EXTERNAL MACHINE HOSES:** 2 years
- BELTS, FITTINGS, FILTER SCREENS, GAUGES:** 2 years
- WATER HEATING SYSTEM:** 2 years
- WATER PRESSURE PUMP: (Through original Manufacturer)** 2 years
- ELECTRICAL COMPONENTS:** 2 years



**ALL MACHINE ACCESSORIES & FRESH WATER TANKS HAVE A 1 YEAR WARRANTY.**

11015 47<sup>th</sup> Ave. W.,  
Mukilteo, WA 98275  
Toll Free U.S. &  
Canada: 800.426.1301  
Phone: 425.775.7272  
Fax: 425.771.7156  
www.hydramaster.com